

**PROPOSED PITCH ROOF CARPORT**

**JOB AREA = 46.46m<sup>2</sup>**

**JOB HEIGHT = 2240mm**

**PITCH HEIGHT = 1422mm**

**POSTS 90 X 90 STEEL TO ATTACH TO PROPOSED SLAB WHICH IS TO BE ARRANGED BY OWNER**

**BEAMS = 200 X 60 STEEL**

**DOWNPIPES TO CONNECT TO EXISTING STORMWATER**

**LAND AREA = 1440m<sup>2</sup>**

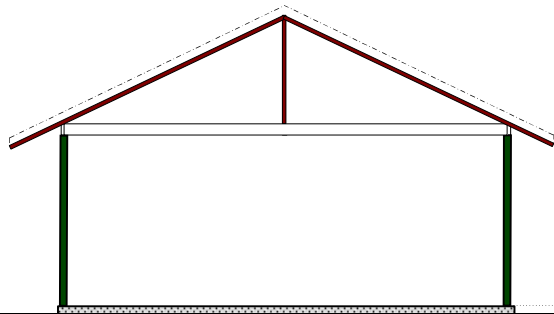

**NORTH ELEVATION**

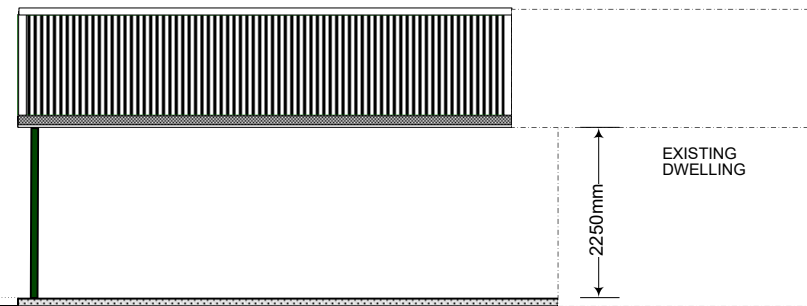
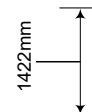
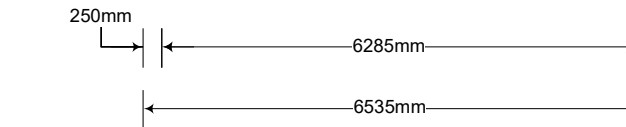

**WEST ELEVATION**

<b>PICTON BROS IMPROVEMENTS PH) 68840899 LIC # 83737C</b>	<b>CUSTOMER:</b> JESSIE PATERSON <b>PANELSPAN PROJECT :</b> PITCH CARPORT <b>SITE ADDRESS:</b> 44 ROWAN STREET URALLA 2358		<b>DESCRIPTION OF PROPOSED WORKS</b> PITCH CARPORT		<b>Drawing Plan Schedule</b> Date Created: _____ Preliminary Drawing: _____ Contract Plan: _____		<b>DATE</b> 23-May-24
	<b>CONTRACT No</b> TA6480 P	<b>SCALE</b> A4 1:100	<b>GRAHAME CHAPMAN</b>	<b>SHEET #</b> 1 of 2	<b>CUSTOMERS APPROVAL</b> Signature:..... Date:.....		
Architectural Plan							

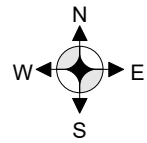
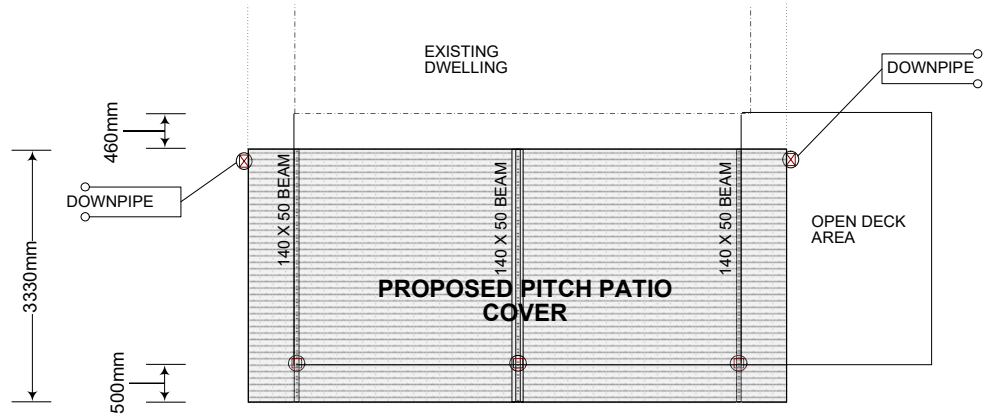

**PROPOSED PITCH PATIO COVER**

**JOB AREA = 19.53m<sup>2</sup>**

**JOB HEIGHT = 2240mm**

**PITCH HEIGHT = 1422mm**

**POSTS = 90 X 90 ALLOY TO ATTACH TO PROPOSED DECK**

**BEAMS = 140 X 50 STEEL TO ATTACH TO EXISTING GABLE END**

**DOWNPIPES TO CONNECT TO EXISTING STORMWATER**

**LAND AREA = 1516m<sup>2</sup>**

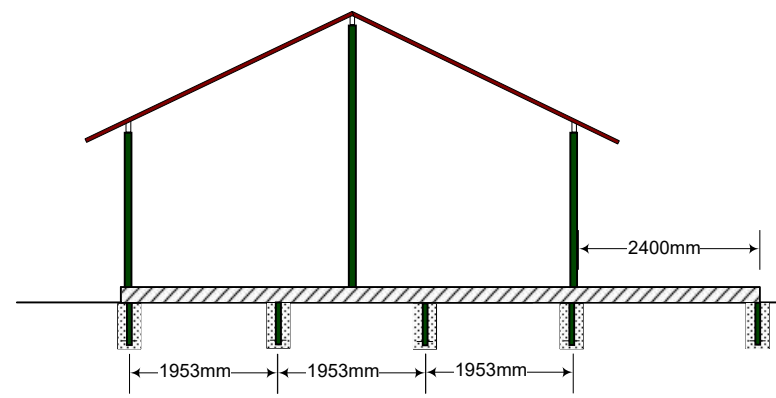
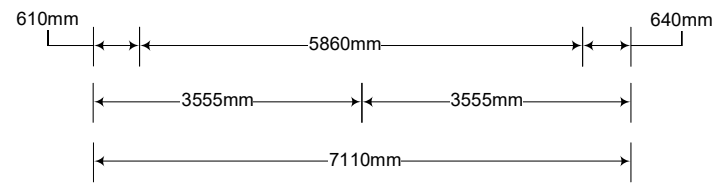

**SOUTH ELEVATION**

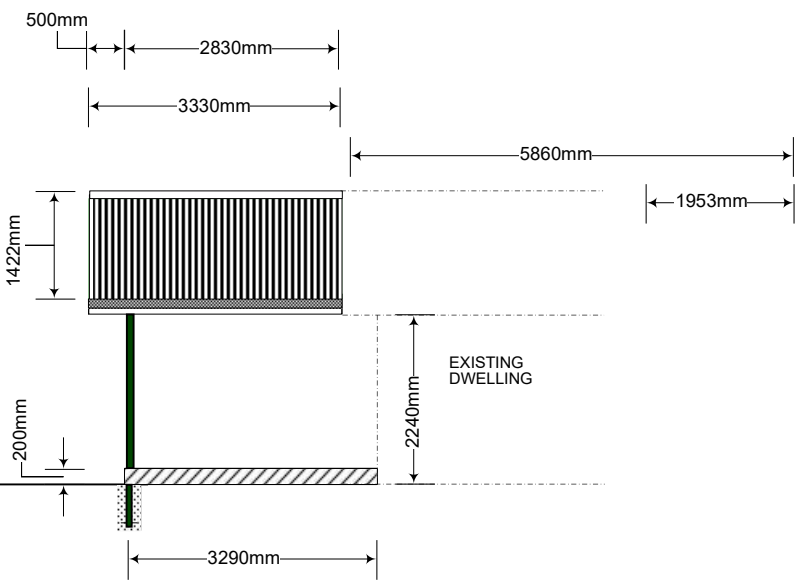

**EAST ELEVATION**

**PICTON BROS  
IMPROVEMENTS  
PH) 68840899  
LIC # 83737C**

Architectural Plan

**CUSTOMER:** JESSIE PATERSON  
**PANELSPAN PROJECT :** PITCH PATIO COVER  
**SITE ADDRESS:**  
 44 ROWAN AVENUE URALLA NSW 2358

CONTRACT No TA6480 P      SCALE A4 1:100

**DESCRIPTION OF PROPOSED WORKS**  
 PITCH PATIO COVER

GRAHAME CHAPMAN      SHEET # 1 of 3

**Drawing Plan Schedule**      **DATE**  
 Date Created: 24-May-24  
 Preliminary Drawing:  
 Contract Plan:

CUSTOMERS APPROVAL  
 Signature:..... Date:.....

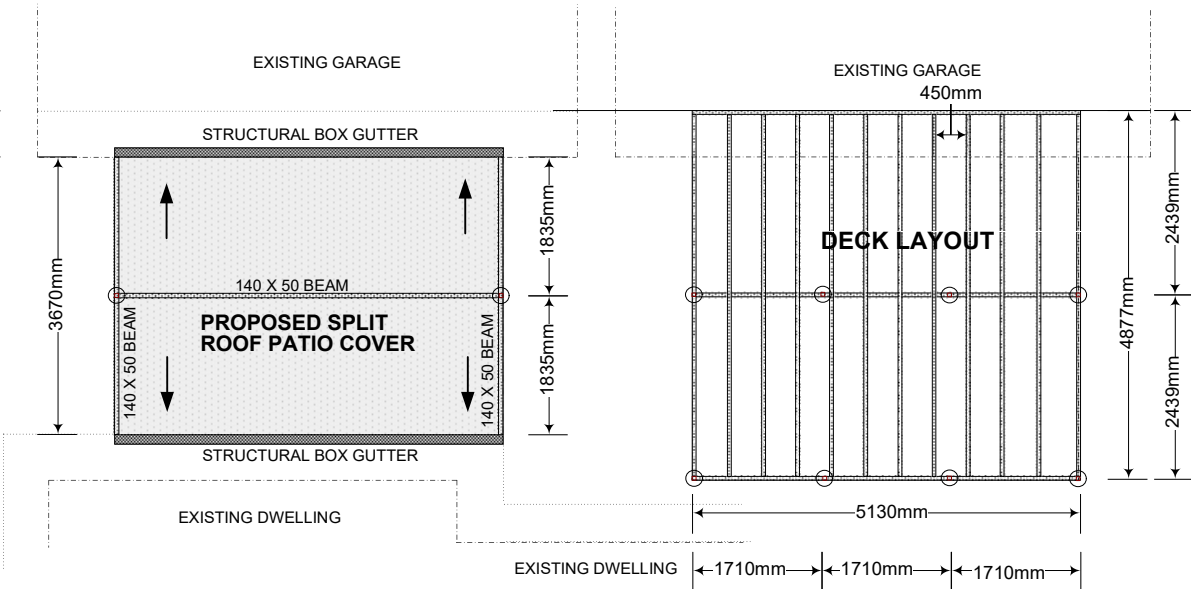
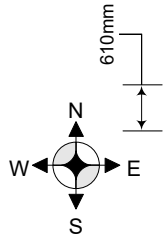

PROPOSED SPLIT LEVEL PATIO COVER TO ATTACH TO FASCIA WITH STRUCTURAL BOX GUTTER

JOB AREA = 18.82m<sup>2</sup>

JOB HEIGHT = 2240MM

EXTENDED ROOF DECK HEIGHT 1134mm

BEAMS = 140 X 50 STEEL

LAND AREA = 1516m<sup>2</sup>

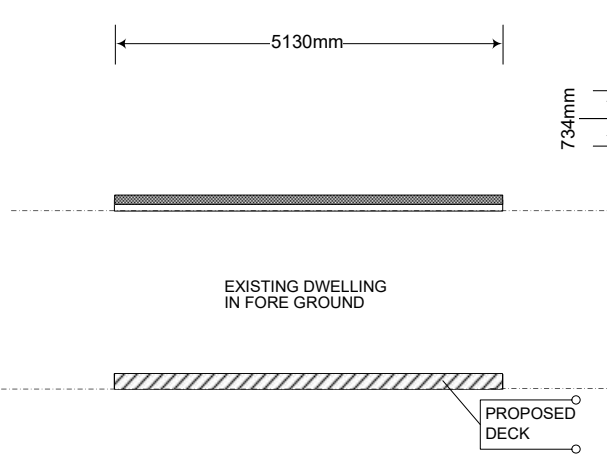
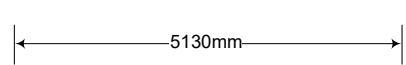
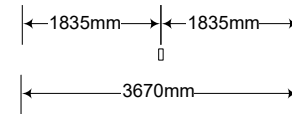
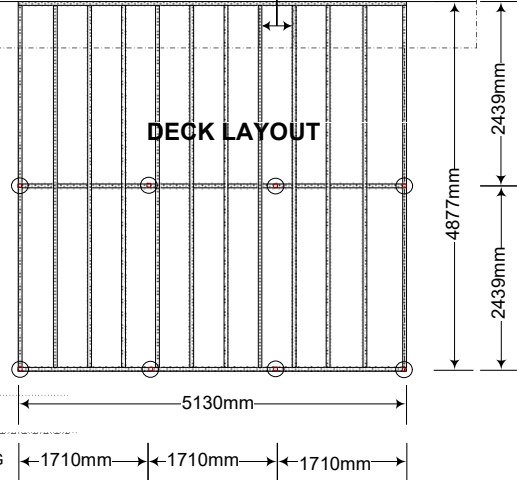

**SOUTH ELEVATION**

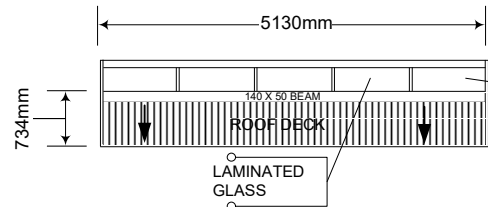

**EAST ELEVATION**

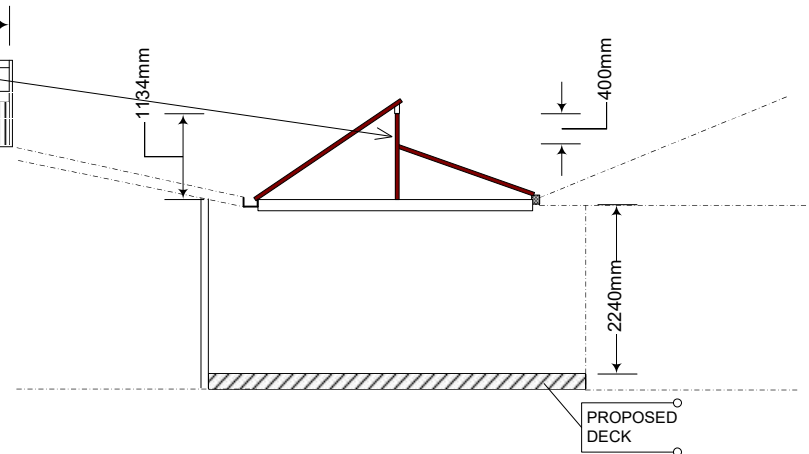

**EAST ELEVATION**

**PICTON BROS  
IMPROVEMENTS  
PH) 68840899  
LIC # 83737C**

Architectural Plan

**CUSTOMER:** JESSIE PATERSON  
**PANELSPAN PROJECT :** SPLIT ROOF PATIO COVER  
**SITE ADDRESS:**  
44 ROWAN AVENUE URALLA NSW 2358

CONTRACT No  
TA6480 P

SCALE  
A4 1:100

**DESCRIPTION OF PROPOSED WORKS**  
SPLIT ROOF PATIO COVER

GRAHAME  
CHAPMAN

SHEET #  
1 of 2

**Drawing Plan Schedule**  
Date Created:  
Preliminary Drawing:  
Contract Plan:

**DATE**  
24-May-24

CUSTOMERS APPROVAL

Signature:..... Date:.....